

Optimized Performance of Cluster Based Protocol for WSN using Adaptive Modulation

Shiv Prasad Kori 1[†],R.K. Baghel 2^{††}, Tarun Kumar Gupta^{†††}Om Prakash Meena^{††††}

JMGPC Burhanpur

MANIT BHOPAL

MANIT BHOPAL

MANIT BHOPAL

Abstract

Wireless Sensor Network (WSN) is used in many applications for instrumentation, diagnostics and control systems. Reliable and continuous operation of wireless sensor network is challenging task due to increasing number of nodes and limited power. The optimization of physical layer parameter like modulation technique, operating frequency, transmission power, hop distance and antenna design play very important role in performance improvement of WSN. There is a trade-off between the reduction of energy consumption using protocol optimization and reliability of communication. In this paper, an adaptive modulation scheme is presented for physical layer of mobile sink based WSN system. The adaptive nature of modulation is based on the distance travelled by the sink. The improvement in the reliability of communication is demonstrated in this paper.

Keywords:

WSN, Cluster, BBM, Communication Overhead, AP.

1. Introduction

The wireless sensor network (WSN) is recent research area of interest of many. The WSN nodes are scattered in the area where monitoring of the object parameters to be done. In sensor node deployment topology are frequently changed. The various sensor nodes are connected to sink and sink may be connect over local computer or remote computer over internet for monitoring the experimental area as shown in Fig. 1. The Sink node receives and relays the event information through internet to the destination by sensing via cluster head or access point in the monitored area.

The WSN nodes are normally once deployed as per the requirement of the object to be monitored, and battery backup power supply could not be changed after deployment. Therefore power consumption is important issue for the WSN. Physical layer plays important role for the communication process of sensor nodes. The WSN node's work is to sense, process and communicate to sink of the network. The WSN node's power

consumption depends mainly on the channel condition, distance from source node to sink, and signal to noise ratio. Testing of the link or channel is done by sending the data over particular distance and depending on the SNR condition the modulation scheme adapted for prolonging the power.

In this paper we have presented the link adaptation using different modulation schemes for cluster based energy efficient WSN in mobile sink scenario.

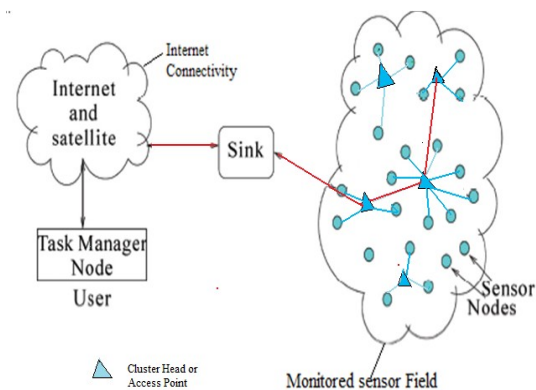

Fig. 1 Communication architecture with WSN system

Wireless sensor network Physical layer

WSN protocol stack shown in Fig. 2 illustrates the protocol layered structure and management planes across the layers. The functions of all layers are conventional and dedicated on protocol for particular layer. Our interest lies in functions of the physical layer in establishing the communication among WSN source and sink nodes.

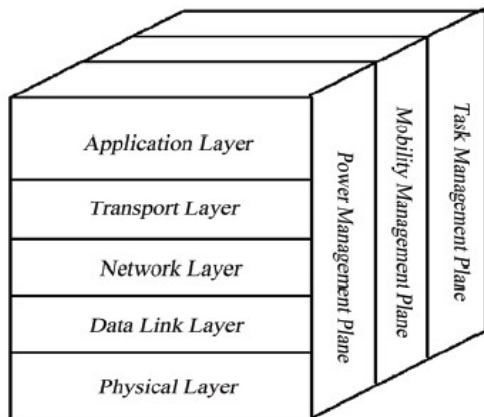

Fig. 2 Protocol Stack of WSN

The functions of physical layer are mainly carrier frequency selection and generation, modulation and demodulation, transmission and reception of data. In the process of communication after sensing the data signal in WSN, the main function of source node is to modulate the sensed data signal. The modulated signal is received, processed and demodulated at the receiving node. The modulation and demodulation are performed by trans-receiver of the source node and sink nodes respectively. The most significant factors in physical layer of WSN power consumption, communication range, signal interference, short duty cycle. In WSN source nodes are having limited power; hence optimization communication process of sensor nodes with less consumption of power is a challenging issue. The power consumption for signal transmission is more as compare to sensed signal processing / computation.

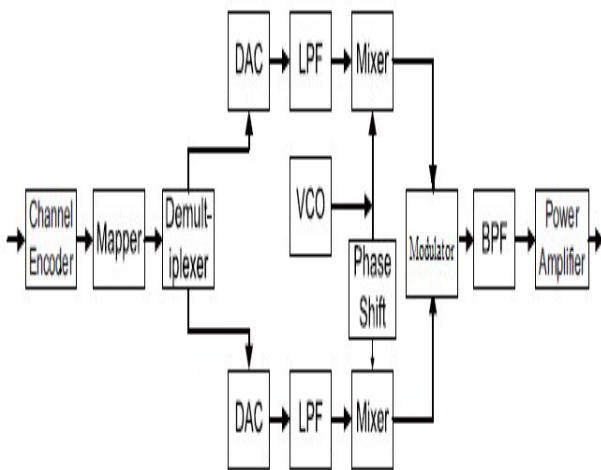

Fig. 3 A typical sensor node Transmitter

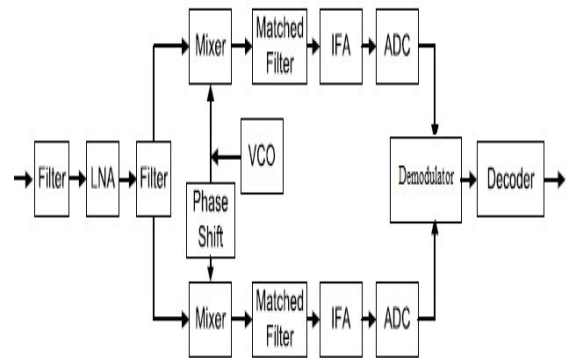

Fig. 4 A typical sensor node Receiver

The power consumption of the circuit components of the transmitter as shown in Fig. 3(excluding the power amplifier) and the receiver as shown in Fig. 4 is defined by author of [6] is fixed but the power consumed by power amplifier also depends on the distance travelled by the sink node in consecution with the processing of the sensed data to be retransmitted.

The choice of modulation scheme which is to be adapted is the factor to be considered, for minimizing the power consumption. The power consumption also depends on channel condition and distance between source and sink nodes of the WSN at a particular time instant.

2. Related Work

There are two main components which contribute to energy loss in a wireless transmission, as the authors of [2] Heinzelman et al. 2002 concluded that energy loss is due to the channel and the fixed energy to run the transmission and reception circuitry. The loss in the channel increases as a power of the hop distance, while the fixed circuitry energy cost increases linearly with the number of hops. This implies that there is an optimal hop distance where the minimum amount of energy is expended to send a packet across a multi-hop network. Similarly, there is a trade-off between the transmit power and the probability of error. In this trade-off, there are two parameters that a network designer can change to optimize the energy consumed: transmit power and hop distance.

The modulation of the system determines the probability of success of the transmission. The author of [3] Wang et al. 2001 illustrated that Changes in the probability of a successful transmission lead to of error is a function of the basic modulation scheme in an AWGN

channel and a block changes in the optimal values for the other physical layer parameters . The probability Rayleigh fading channel, and its dependency on the noise level of the channel and the received energy of the signal (i.e., it dependence on the SNR), is illustrated by by[6]Holland,Wang, talvi etc (2009) by optimization these parameter .Authors concluded that energy per successful bit transmission become independent of noise for optimum fixed distance. In this study author investigated the problem of energy-efficient transmission of data over a noisy channel, focusing on the setting of physical layer parameters. The authors have derived a metric called the energy per successfully received bit, which specifies the expected energy required to transmit a bit successfully over a particular distance given a channel noise model.

In [16] Maryan Soltan, Hwang, Pedram (2008) has suggested that WSN node location adapts the modulation scheme as function of distance (which is fixed for particular location of node)in hierarchical manner. In [17] the author Yu Yadong Zhu Rong Dai Jigning in 2009, used signal strength available to judge the channel condition and accordingly adaptive modulation applied for increasing lifetime of WSN. They had suggested that quality of channel estimated using signal strength from receiver and adjust the mode of modulation for reducing the BER and retransmission in turn reduced power consumption.

In [18] A game theoretic approach has been suggested by authors R. Valli and P. Dananjayan in june-2013, for adaptive modulation and coding for lifetime enhancement of WSN ,they have considered the residual energy of node and accordingly modulation scheme adapted .In December 2013 they had applied this game theoretic approach in MIMO WSN considering the residual energy of node with adaptive modulation.

In [19] author M. sheik Dawood etc had done the performance analysis of MSK modulation and coding in energy efficient sensor network protocol. They had shown the appropriate combination of modulation and channel coding to improve the lifetime of energy efficient clustered WSN. There is homogeneous environment of MSK or with combination of other modulation for more distance placed node from cluster head and MSK for centrally located node. All networks is stationary nature with no mobility factor. But if distances of communication range increase due to the velocity of mobile sink then reliability of uninterrupted communication will be affected and rate of communication failure will increase. In this paper the authors have considered the effect of distance variation

due to mobile sink velocity on SNR and accordingly adaptive modulation scheme adapts the modulation type for maintaining the reliability.

2.1 Error rate of different modulation scheme for WSN

The various modulation techniques are used in the WSN communication system. The probability of error for communication is strongly depends on the digital modulation used for data transmission. The digital modulation techniques mainly given as below,

- BPSK
- QPSK
- QAM-M

2.2 Binary Phase Shift Keying (BPSK) Modulation

Let the data transmission by a node in WSN is sequence x(n) then the modulated sequence may be given as in equation(1):

$$v = \begin{matrix} -1 & x(n) = 0 \\ +1 & x(n) = 1 \end{matrix} \tag{1}$$

Due to maximum phase space is available in this modulation scheme this will give minimum error rate.

The error rate of BPSK for WSN is given as in equation(2):

$$P_c = Q \left(\sqrt{\frac{2E_s E_x}{N_0}} \right) \tag{2}$$

Where energy per received symbol Es,

$$E_{Rx} = \frac{E_s \Gamma_x}{\alpha d^n},$$

The parameter α is reciprocal of product of amplifier efficiency (L) and loss in channel [6].

2.3 Quadrature Phase Shift Keying (QPSK) Modulation

Data transmission by a node in WSN is Signal S(t) is given as[15]equation(3):-

$$S(t) = \sqrt{\frac{2E_s}{T_s}} * \text{Cos} \left[2\pi * f_c * t + \frac{(i-1)\pi}{2} \right] \tag{3}$$

Where I = 1, 2, 3, 4

QPSK has twice the bandwidth efficiency of BPSK, since two bits are transmitted in single modulation

symbol. The bit error rate (probability of error) in QPSK is given by equation (4):

$$P_{e,s} = Q\left(\sqrt{\frac{2E_{min}}{N_0}}\right) \tag{4}$$

$$E_{min} = E_{s,Rx,dij} = \sqrt{2E_s} = 2\sqrt{Eb}$$

Euclidian distance successive signal point in the constellation, Q is the Q function.

Probability of error in QPSK is same as BPSK, but twice as much data can be sent in the same bandwidth.

2.4 Quadrature Amplitude modulation (QAM)

Let the data transmission by a node in WSN is signal $S_i(t)$ then the modulated sequence may be given as [15]equation(5):-

$$S_i(t) = \left(\sqrt{\frac{2E_{min}}{T_s}}\right) * a_i * \text{Cos}(2\pi * f_c * t) + \left(\sqrt{\frac{2E_{min}}{T_s}}\right) * b_i * \text{Sin}(2\pi * f_c * t) \tag{5}$$

(5)

for $i=1,2,3, M$ and a_i, b_i are the pair of independent integer chosen according to location of signal point. QAM does not have constant energy per symbol nor does it have constant distance between possible symbol states.

The error rate of QAM for WSN is given as in equation (6):

$$P_{e,s} = 4 * \left[1 - \frac{1}{\sqrt{M}} * Q\left(\sqrt{\frac{2E_{min}}{N_0}}\right) \right] \tag{6}$$

(6)

It is noted that M-array QAM does not have constant energy per symbol nor does it have constant distance between possible symbol states. It reasons that the particular value of $S_i(t)$ will be detected with higher probability than others.

Power spectrum and bandwidth efficiency of QAM modulation is identical to M-array PSK.

In terms of Power efficiency QAM is superior to M-array PSK.

In our analysis and simulation we have taken only QPSK, QAM8, and QAM 16.

3. System description

The WSN with mobile sink has been implemented on MATLAB test bench. The various performance Parameters are evaluated on the test bench. The schematic diagram of the system is shown in Fig. 5.

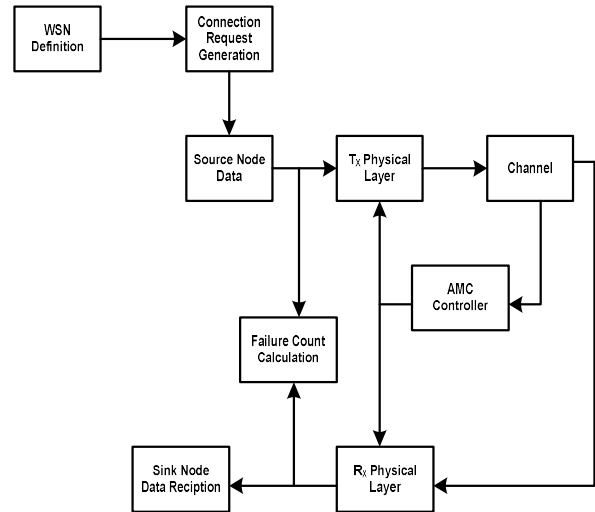

Fig.5 Schematic diagram of implemented WSN system

The system presumes that sink is well equipped with sufficient power supply, computational and memory capacity. With movement of sink with certain velocity, sink moved beyond the threshold distance as parameter of velocity, the channel condition SNR with distance variation characteristics, the AMC controller switches the modulation type for sustained communication. In our WSN system sender sends the information to the sink node which could be in moving condition, when sink crosses the threshold distance with poor SNR condition number of failure count of the communication link increases, upon increasing the failure count with acceptable BER decreases and reliability of the system decreases in particular modulation ,in this condition AMC controller switches the system in less failure count providing modulation type in given SNR and BER condition, so that reliability could be maintained.

3.1 Reliability Analysis

In Wireless sensor network critical event data collected by the sensor nodes need to be reliably delivered to the sink for successful monitoring of an environment. Therefore, given the nature of error prone wireless links, ensuring reliable transfer of data from resource constrained sensor nodes to the sink is one of the major challenges in WSNs. Reliable transfer of data

is the surety that the packet carrying event's information arrives at the destination.

One way of achieving reliability in terms of recovering the lost packets is through the use of retransmissions of the lost packets. Retransmissions can either be performed on end-to-end or hop-by-hop basis. End-to-end re-transmission requires only the source node that generated the packet to re-transmit the lost packet.

For a given network. Let there are N nodes connected through the access point and event generation per second is q_i . The single access point will also deal with other AP and mobile sink the distance between access points is fixed but AP to sink is continuously changing with change in the position of sink.

The reliability of the network may be given as

$$R = f(v, M_i, up_i, q_i);$$

Where v is velocity of sink, M_i is modulation order, up_i is update time and q_i is event generation per second.

The communication overhead reduced in cluster based techniques in comparison of BBM technique so energy consumption reduced in cluster based techniques. But the reliability decreases as number of node increases in cluster techniques and there is trade-off of reliability and communication overhead for this protocol optimization [13].

4. Numerical simulation and Result

The simulation has been performed with the test bench developed in the MATLAB. The following parameters are used for the simulation.

Table 1: Simulation Parameters

S. No.	Parameters	Value
1	Number of node	50
2	Network length	1000 meters
3	Modulation techniques	QPSK, QAM8, QAM16,
4	Transmitter power	2 watt
5	Antenna Type	Omni direction array
6	Directivity	11 dB
7	SNR	38-58db
8	BER	10^{-1}
9	Threshold Failure Rate	10^{-7}

The results are given for adaptive modulation based WSN communication in term of failure rate. To accomplish the adaptive modulation scheme the

requirement the antenna radiation pattern has been studied with the distance. This provides the SNR as a function of distance. Distance between the end nodes to sink depends on the velocity of the sink. The various results of simulation are given as follows:

4.1 SNR variation with distance of communication

The signal power decays with distance by inverse cubic relation. The noise power are taken as -80, -90, -100 dbm considering the different transmission bandwidth for calculating the SNR value. The transmitted power at node is considered as 2 watt. The theoretical calculation of SNR with distance from transmitter antenna at different noise level is shown in the Fig.6. Rapid decay of the signal level at the distance progress from node and then it slow down the decay after a long distance.

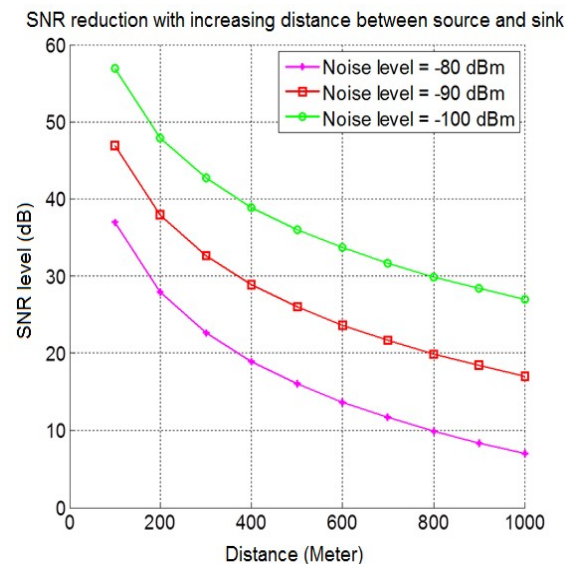

Fig.6 SNR reduction with distance

4.2 BER variation with SNR of communication

The impact of the decrement of SNR produces the error in the transmission. Bit error rate (BER) is one of the basic parameter to measure the error in transmission. The theoretical BER performances for different modulation scheme on AWGN channel are shown in Fig. 7.

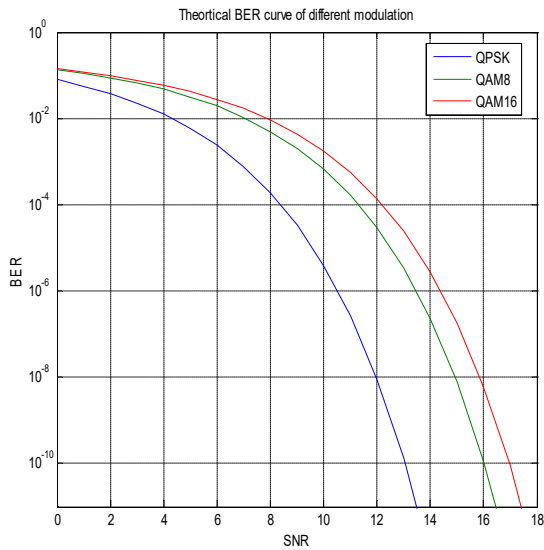

Fig.7 Variation of BER with SNR

4.3 BER variation with SNR of communication for fading channel

For wireless node we have also considered the wireless channel. We have used the Rayleigh fading channel for evolution of BER performance. BER performances for different modulation scheme on this channel are shown in figure 8.

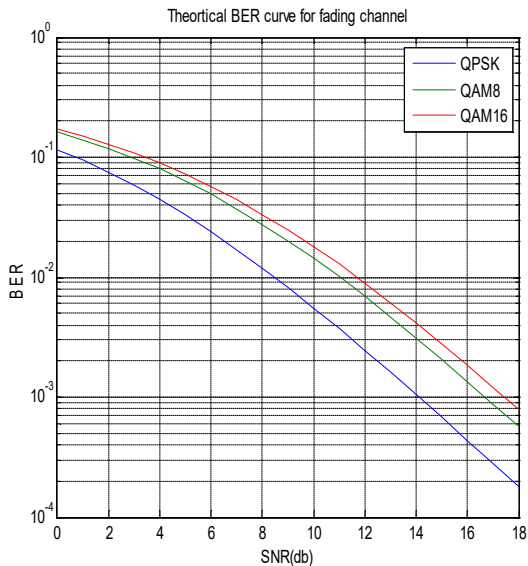

Fig.8 Variation of BER with SNR in fading channel

4.4 Failure rate for different modulation scheme with velocity of sink

The BER performance and SNR evaluation are used for simulating the failure rate in WSN system with various modulation techniques. The trend of communication failure rate with mobility of sink in QPSK, QAM8 and QAM-16 are illustrated in figure 9. The failure rate increases with increase in velocity of the sink alternatively with the increment of the travelled distance. To maintain the reliability of the communication, switching of modulation scheme is recommended.

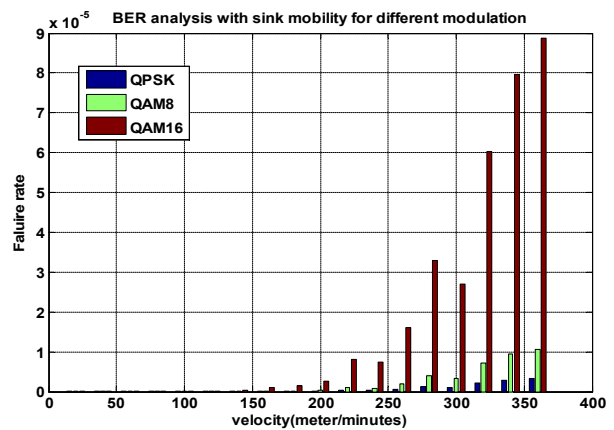

Fig.9 Failure rate with velocity of sink for different modulation

The AMC has been designed for WSN system with considering the error threshold. The threshold failure rate along with failure rate of different modulation scheme is shown in the Fig. 10. When velocity increases distance between source node and sink node increased, due increased distance with threshold value the communication failed. QPSK failure reached earlier with increment in velocity of sink, than QAM-8, and QAM 16.

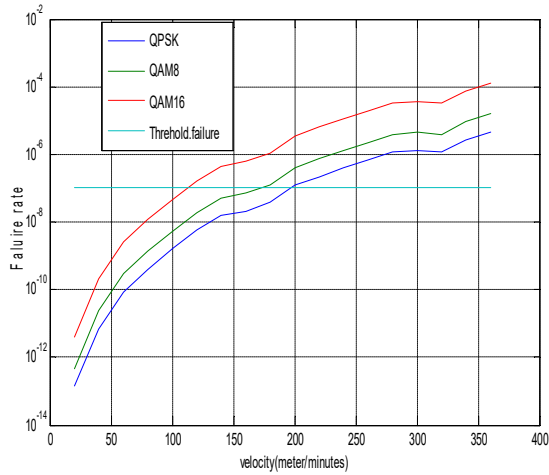

Fig. 10 Combined graph for failure rate with velocity of sink for different modulations

4.5 Adaptive modulation scheme with velocity of sink

To maintaining the failure rate between 10^{-7} and below, switching between different modulations is illustrated in Fig. 11. As shown in figure up to velocity of order of 20 to 120 meter/minute QAM-16 used when velocity increased greater than 120 meter/minute up to 160 meter/minute QAM-8 adapted and further when failure rate increased in more velocity QPSK modulation is adapted. This adaptive scheme is sensed at the transmitter end and accordingly the modulation scheme is implemented.

Table 2: Improvement in the system communication

Velocity (m/s)	Modulation used	Failure rate improvement	Spectral efficiency
50	QAM-16	--	2 times over QPSK
100	QAM-16	--	2 times over QPSK
150	QAM-8	1order improvement compare to QAM16	1.5times over QPSK
200	QPSK	1order improvement compare to QAM8and2 order improvement compare to QAM16	---

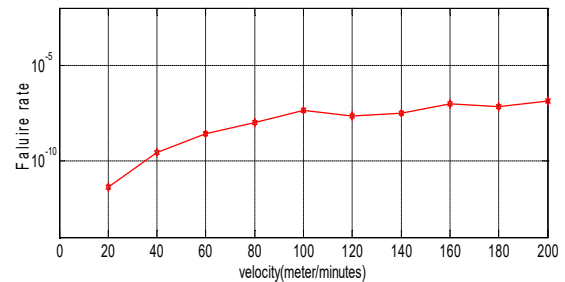
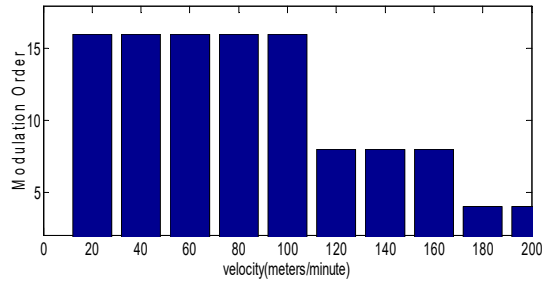

Fig.11 Adaptive modulation and Failure rate with velocity (distance) of sink

5. Conclusion

As we observed that signal to noise ratio decreases (Fig. 6) with increase in distance .when mobile sink moves with higher speed it cross the threshold distance and SNR reduced , then we had used adaptive modulation scheme based on distance travelled . By simulation we have seen that Reliability is maintained in varying speed with certain distance crossed the probability of error increased, and control system automatically switched to another modulation scheme so that reliability could be maintained. Reliability is improved due to AMC technique which automatically adapts the effect of distance (velocity of sink) with failure count.

References

[1] I.F. Akyildiz, Su. Weilian, Y. Sankarasubramaniam, and E. Cayirci, "A survey on sensornetworks." Communications Magazine, IEEE, Vol. 40, no.8, pp. 102-1148, 2002.

[2] W. Heinzelman, A. Chandrakasan, and H. Balakrishnan., "Application specific protocol architecture for wireless micro sensor networks," IEEE Transactions on Wireless Communication, vol.1, no.4, pp. 660-670, 2002.

- [3] A. Wang, S. Chao, C. Sodini, and A. Chandrakasan., "Energy efficient modulation and Mac for asymmetric micro sensor system," in Proc. IEEE Int Symp. Low Power Electronics and Design, pp.106–111, 2001.
- [4] R. Zhang, M.J. Lee, and S.S. Joo., "Distributed mobile sink support in wireless sensor networks," in Proc. IEEE MILCOM, 2008.
- [5] S. Nithyakalyani, and Suresh., "Data Relay Clustering Algorithm for Wireless Sensor Networks: A Data Mining Approach" *Journal of Computer Science*, Vol.8, no.8, pp. 1281-1284, 2012.
- [6] M. Holland, Tia nqi wang, B. Tavli, A. Seyedi and W. Heinzelman., "Optimizing physical layer parameter for wireless sensor networks," ACM journal, Vol.7, no.4, pp. 28.1-28.20, 2009.
- [7] M. Pandey, and S. Verma., "Energy Consumption Patterns for Different Mobility Conditions in WSN," Scientific Research Wireless Sensor Network, pp. 378- 383, 2011.
- [8] K. Akkaya and Mohamed Younis, "A survey on routing protocols for wireless sensor networks," Ad Hoc Networks, pp.325–349, 2004.
- [9] K. Guan and L.M. He, "A Novel Energy-Efficient Multi-Path Routing Protocol for Wireless Sensor Networks," in CMC conference, vol.3, pp. 214-218, 2010.
- [10] S. Dulman, T. Nieberg, J. Wu, and P. Havinga., "Trade-Off between Traffic Overhead and Reliability in Multipath Routing for Wireless Sensor Networks," in IEEE conference, vol.3, pp.1918-1922, 2003.
- [11] S.P. Kori, and R.K Baghel., "Evaluation of Communication Overheads in Wireless Sensor networks." *International Journal of Engineering research*, Vol.2, no.2, pp 171-175, 2013.
- [12] S.P. Kori, and R K Baghel., "Performance Comparison in Terms of Communication Overhead for Wireless Sensor Network Based on Clustering Technique." *international Journal of Electronics Communication and Computer Engineering*, Vol.4, no.3, pp. 212-217, 2013.
- [13] S.P. Kori, and R K Baghel., "Reliability Analysis of the Cluster based communication protocol for WSN with Mobile Sink" *International Journal of Computer Applications*. Vol.82, no.5, pp. 314-319, 2013.
- [14] T.S. Rappaport, "wireless Communications Principles and Practice," Second Edition, Pearson Publication, 1996.
- [15] Mathworks 2012 . <http://www.mathworks.com>.
- [16] S., Maryan, and Hwang Pedram, 2008. "Modulation Aware Energy Balancing in Hierarchical Wireless Sensor Network." *Int. Symp.on Wireless Pervasive Computing, 2008*.
- [17] Yadong ,Yu,Zhu Rong and Dai Jining., "An Energy – Efficient Physical Layer Adaptive Modulation Scheme for Wireless sensor networks ."In *Proc. ICISE, IEEE*, pp.3963-3966, 2009.
- [18] Valli, R., and P. Dhanayanjan , 2013. "Adaptive Modulation and Coding for Lifetime Enhancement of WSN Using Game Theoretic Approach." *WSES Transaction on communications*, Vol.12. no.6, pp. 256-261, 2012.
- [19] D.M. sheik , R.Aiswaryalakshmi, and G.athisha., " Performance Analysis of MSK Modulation and Coding in Energy Efficient Sensor Network Protocol." *Journal of Theoretical and Applied Information Technology* , vol. 56, no.1, pp.432-437, 2013.



Shiv Prasad Kori received the B.E. degree in electronics and telecomm Engineering in 1994 from G.E.C. Jabalpur, India and M. Tech degree in Digital systems from MNNIT Allahabad in 2003. He is working as senior faculty in JM Polytechnic Burhanpur(M.P) ,India.



Dr. R.K Baghel received the B.E degree in Electronics in 1990 the M.TECH degree in Digital signal Processing in 1997, and Ph.D in Optical communication from University of Bhopal. From 1992-2000 he involved in the equipment

development for synchronous optical development. Recently he is involved in low pressure measurement equipment using capacitive transducer and LCD/LED driver structure development for low power high speed & their power management. He is Professor in MANIT BHOPAL from 1991-till date. He has authored or coauthored over 15 refereed international journal and conference papers.



Tarun Kumar Gupta received B.E (Electronics and Communication) in 2001, M.Tech. degree in Digital Systems in 2003, and the Ph.D. degree in the field of VLSI design in 2013. Currently, he is working as Assistant Professor in Electronics and Communication Engineering in MANIT, Bhopal, India. His fields of interest are

Low power VLSI design and semiconductor devices. His research mainly includes implementation of low power dynamic circuits. He has nearly 30 publications in various international conferences and journals. Communication Engineering.



O. P. Meena, He received the Bachelor of Engineering (B.E) in Electronics and Communication from University of Rajasthan in 2006, Master of Technology (M.Tech.) from Indian Institute of Technology, Kanpur in 2009 and Ph.D. from Maulana Azad National Institute of Technology (MANIT), Bhopal in 2015. He worked as lecturer

in Department of Electronics and Communication Engineering, AITS, Rajkot, India from July 2009 to May 2010. Since June 2010, He is working as Assistant professor in department of Electronics and Communication Engineering, MANIT Bhopal. His research interest includes Signal Processing and Communication Engineering.