

# Early Detection of Rice Leaf Blast Disease using Deep-Learning Techniques

Syed Rehan Shah<sup>†</sup>, Syed Muhammad Waqas Shah<sup>††</sup>, Hadia Bibi<sup>†††</sup>, Mirza Murad Baig<sup>††††</sup>  
<sup>†</sup>[Syedrehan4892@gmail.com](mailto:Syedrehan4892@gmail.com), <sup>††</sup>[smwaqas@numl.edu.pk](mailto:smwaqas@numl.edu.pk), <sup>†††</sup>[syedahadiakhalil@gmail.com](mailto:syedahadiakhalil@gmail.com), <sup>††††</sup>[murad.baig@numl.edu.pk](mailto:murad.baig@numl.edu.pk)

<sup>†</sup>Muhammad Nawaz Shareef University of Agriculture Multan, Pakistan

<sup>††</sup>Department of Computer Science, National University of Modern Languages, Islamabad, Pakistan

<sup>†††</sup>Department of Computer Science, BZU Multan, Pakistan

<sup>††††</sup>Department of Computer Science, National University of Modern Languages, Islamabad, Pakistan

## Abstract:

Pakistan is a top producer and exporter of high-quality rice, but traditional methods are still being used for detecting rice diseases. This research project developed an automated rice blast disease diagnosis technique based on deep learning, image processing, and transfer learning with pre-trained models such as Inception V3, VGG16, VGG19, and ResNet50. The modified connection skipping ResNet 50 had the highest accuracy of 99.16%, while the other models achieved 98.16%, 98.47%, and 98.56%, respectively. In addition, CNN and an ensemble model K-nearest neighbor were explored for disease prediction, and the study demonstrated superior performance and disease prediction using recommended web-app approaches.

## Keywords:

*machine vision rice blast disease detection, image processing, transfer learning, deep neural networks, web-app*

## 1 Introduction

Rice is a highly produced, nutritious food that is a significant element of the world's diet. Rice is still the essential food and grain for people and is grown more than any other prominent grain these days [1]. The rice kernel contains iron, copper, zinc, and other nutrients, making it healthy. Rice comes in several varieties, including brown, red, black, and basmati rice [2]. The rice kernel is beneficial since it contains iron, copper, zinc, and other nutrients. Rice was grown on 164.19 million hectares worldwide in 2020, and its global trade expanded faster than any other crop [3]. In the crop year 2019 to 2020, total global rice production was 497.7 million metric tons. China, Thailand, Bangladesh, Pakistan, Brazil, and Indonesia produced 52.9 percent of worldwide production and used 480 million metric tons [4]. Rice is considered in Pakistan the "Money Crop," accounting for 3.1 percent of agriculture and 0.6 percent of Pakistan's GDP [5]. According to the Economic Survey of Pakistan (FY-2020), Pakistan is the top rice

exporting country worldwide, with a billion dollars in agricultural sectors [6].

Pakistan is currently dealing with increasing water constraints and viral crop diseases, which are causing massive losses in rice quantity and quality [7]. It is now suffering from various diseases, divided into two categories: bacterial and fungal infections. Without recommended care, protection, and the use of appropriate pesticides, these diseases can be more dangerous for plant survival [8]. Rice Leaf Blast disease is one of the environmental factors leading to decreased rice yield worldwide [9]. Because of its extensive distribution and capacity to persist in various environmental situations, it has become a dominant, dangerous disease in Pakistan. The rice leaf blast is caused by *Magnaporthe grisea* [10]. It is one of the most destructive diseases in rice fields. It is responsible for 10-30% of yearly yield losses [11]. Under some favorable circumstances, it can worsen and devastate the whole rice yield in 15 to 20 days and up to 100% of the crop loss [12]. Nowadays, farmers are practicing a traditional method for the identification of disease in rice plants by simply observing the plant condition with the naked eye. For this purpose, a team of professionals with expertise in plant disease monitoring and identification can be very costly when applied to a vast agricultural area. For disease detection in leaves, an automatic system is necessary to identify diseases by just capturing an image of rice leaves.

Therefore, in this study, we introduced the connection-skipping ResNet module by joining the pre-trained Dense layer [13] on ImageNet [14] to overcome the degradation problem of unique image features in deep neural networks, increase the disease detection accuracy and decrease the computational complexity. We freeze the top input layer of the module by defining it none trainable and adding batch normalization and a

Manuscript received April 5, 2024

Manuscript revised April 20, 2024

<https://doi.org/10.22937/IJCSNS.2024.24.4.25>

ReLU layer of 512 neurons; then, a flattened Softmax layer was added with the two classes as a top layer in the defined network. Then the stated connection skipping module was formed and used for the rice leaf blast disease prediction. The remainder section presents the dataset collection and preprocessing by defining the comprehensive methodology to attain the chore of rice blast disease detection along with the proposed architecture. The third section elaborates on the experiments and evaluation of results and a comparative analysis of performed techniques.

## 2. Literature review

Rice cultivation and export is a major source of foreign money in Pakistan. The statically time series (1972-2011 years data) approach was used to analyze rice growth, supply, farming area, and trade [15]. Food is the most vital component of human life. Rice insecurity now influences the quality and availability of rice in Pakistan. Environmental efficiency and cleanliness are essential for rice cultivation by considering different types of rice in 2006 from the districts of Gujranwala, Sheikhpura, Sialkot, and Hafizabad. It saves Rs 297 per acre and Rs 1,307.3 million based on the overall productivity of rice crops across all agricultural districts in Punjab [16]. Rice disease detection using machine learning algorithms is a novel example of advancement [17]. The automated diagnosis system is now based on convolutional neural networks (CNN), which are considered one of the best learning algorithms [18]. Traditional disease identification methods are time-consuming and require expertise, such as the extraction of size, color, texture, or vein for the disease area are now using deep learning to improve the detection accuracy. Rapid advancement allows researchers to adopt transfer learning as part of deep learning terminology. The author [19] used a convolutional neural network trained on 2906 images of healthy people and 2902 diseased images. The researcher conducted a comparison study of composed algorithms and other traditional algorithms. However, the proposed model results show the highest accuracy level of feature extraction rather than crafted features like texture or binary. Besides SVM, CNN achieved 95% accuracy in detecting rice diseases. A well-performing and accurate detection of rice diseases could be beneficial for farmers to overcome the financial decrease and the adoption of

early precautions. The recent advancement in the CNN-based model has significantly improved its image base classification accuracy. The deep learning approaches have been developed by [8] for detecting rice diseases and pests using plant images. The best scale architecture models, such as VGG16 and Inception V3, were used and fine-tuned to identify rice diseases. After all, the models were evaluated on a large-scale dataset.

The CNN models break down into two stages of architecture for mobile identification using MobileNet and SqueezeNet. The experiments show the proposed model scored an accuracy of 93.3% significantly by reducing over-fitting and fewer generalization problems. Nowadays, machine vision approaches help enhance the agricultural sector's productivity. Using deep learning to identify rice diseases depends on the best features of plant images. The researcher [20] integrated machine learning techniques to classify rice varieties using texture features. They collected image data and performed preprocessing for image enhancement to obtain refined image datasets [21]. They extracted histogram, texture, and binary [22] features to train models like Meta begging and tree J48. One of the models attained 97.4% of accuracy. Over the principles of biotic factors, rice grains are affected by soil fertility, bacteria, and diseases. Such diseases are prevalent and hard to identify [23]. The CNN model was proposed by [24] to be trained on 6330 images and YOLO v3 classifier for object detection on rice plant images. The experiments showed that YOLOv3 provided the best precision at 79.19% in detecting rice leaf diseases. The overall results were 75.92% for Mask-R CNN, 70.96% for Faster R-CNN, and 36.11% for Retina-Net. Selecting features from an image is an important factor in machine learning classification. The algorithms are dependent on features. In this way, the use of convolutional neural networks shows the high quality of data for the identification of rice plant diseases. The author [25] introduced the deep features for rice leaf disease identification on 5932 images of rice diseases, including rice leaf blast. The simulation of different transfer learning models were applied to get better results. the performance were measured by combining CNN with SVM by learning counterparts. The transfer learning models such as VGG16 and 19 and SVM, F1 score was 0.98 percent. The dynamic segmentation base algorithm, including minimum and maximum distance, was applied for the

classification of rice diseases by [26] Firstly, the proposed method was used to address the different types of rice diseases, by removing extra noise, image blur, and a soothing background of images for higher accuracy. Multilevel interference was used with K-means clustering for optimizing local prediction [27]. The model combined CNN layers with R-CNN for the target frame and detected the rice diseases with an accuracy of 96%. The method indicated that using deep learning schema increases the possibilities of farmers, especially for detecting rice leaf blasts. Rice is one of the most stable crops for any agricultural economy [28]. Rice diseases become problematic by affecting crop production and the economy. Nowadays, plants are being affected by diseases like leaf blasts, bacterial blight, and brown spots. Detecting such rice diseases using deep CNN combining naive Bayes generates an economic advancement [29]. The author [30] constructed an image processing-based machine learning algorithm that allows the detection of diseases based on color, texture, and outlining [31]. The model CNN selected those features and combined them with the naive Bayes algorithm for the classification of rice diseases and has brained the accuracy of 95%. Proper management and detection is required to control rice diseases and pests [32]. Rice diseases cause a 30 percent loss on average every year [11]. The author [33] annotates each image's sick portion by introducing the solution by contributing to ICT. Unlike previous algorithms, a localized categorization for each picture segment uses Mask RCNN to locate and measure sick plant areas in different districts of Pakistan

### 3. Methodology

As discussed earlier, this study focuses on detecting rice leaf blast disease. The image dataset was collected from the online repository, and for experiment work, all the images were labeled according to the class belonging to

[16]. This technique estimates agricultural damage by achieving 87.6% accuracy on the provided dataset against 58.4% without localized information. The author [34] employs a Support Vector Machine (SVM) image-processing strategy to investigate and categorize three rice crop illnesses. There are two stages to this process: training and symptom prediction [35]. Leaf diseases are detected by a trained classifier in this method.

The suggested study optimizes the parameters ( $\gamma$ ,  $\nu$ ) of SVM. According to the findings, the suggested method has 94.16% accuracy. The researcher adopted a convolutional neural network algorithm by importing Inception and Resnet architecture. They analyze the image classification and segmentation using datagen library and optimized the models for the detection of rice diseases including rice leaf blast. The approach is optimized for the classification of diseases with the accuracy of 95% respectively. However, for this study we utilized CNN based models on public rice disease dataset and those convolutional models provided slightly sufficient results in terms of accuracy, speed and space as compared to the conventional machine learning models [36].

Figure 1. However, Symptoms of rice leaf blast disease that appear from the seeding stage to plant maturities are briefly discussed in Table 2.

Initially, about 2000 images were collected, including rice leaf blast and healthy leaves, from an online machine-learning dataset repository known as Kaggle [37]. Furthermore, all the photos were resized to pixel-dimension  $224 \times 224$  and stored in train and validation folders on a cloud server. The collected dataset was divided into the training dataset, used to feed the models; the validation dataset to validate model

training parameters; and the testing dataset, used to predict leaf blast disease.

Table 1 shows the train and tests split percentages of selected images from diseased and healthy classes. Moreover, by using a preprocessing technique, the images were resized to accommodate the models' input requirements, and as per the formed dataset, we

artificially generated a new dataset using data augmentation technique; for instance, image rotation, shear range, and zoom range are utilized as input to the proposed models for training and the trained model was deployed using web service for the prediction of rice leaf blast disease depicted in Figure 6.

**Table 1.** Organization of dataset [37]

Total Images	Diseased Images	Fresh Images	Training split
2000	1200	800	70%,20%,10%

**Table 2.** local Symptoms of rice leaf blast disease [38]

Local Symptoms	Blast Patterns
Leaf symptoms	Usually, the leaf showed diamond-shaped lesions with a white or grey-brown border. Diameter of 0.58 or 0.39 inches
Collar symptoms	Typically infection on the leaf describes the area by color rot at the junction of the leaf blade.
Neck symptoms	A grayish-brown discoloration appears on a leaf.

As discussed earlier, ResNet represents the first concept of connection skipping to overcome the degradation problem of unique image features in deep neural networks, and it also counters another gradient vanishing problem by introducing a batch normalization layer and max pooling layer with proper initiation of weights. However, Residual Networks is a standard neural network that serves as the base for many machine vision applications. This version was the finalist of the 2015 ImageNet large-scale visual recognition challenge.

We freeze the top input layer of each module by defining it as none trainable and adding batch normalization and a ReLU layer of 512 neurons, which ensures enhanced gradients having better norms; after all, a fully connected layer with Softmax function initialized on training classes on the modified residual network; thus, the first part of the proposed methodology, used pre-trained module as expressed in Equation (i).

$$X_l = H_l(x_0, x_1, \dots, x_{l-1}) \quad (i)$$

Where  $i$  is the CNN's layer number,  $x_0, x_1 \dots x_{l-1}$  indicates cascading the image features from layers 0 to  $l-1$  as the source of the following layer, similar to how the ResNet module works. The above layers have served as a fundamental feature extractor. The second part focused on multi-scale edge detection in the following steps.

- Initially, the network loaded with ImageNet weights and augmented labeled images according to the class category, which provides better performance in the detection of images.
- Secondly, convolutional blocks extracted the features and stored them in a NumPy array to solve a new prediction problem. Additionally, freezing the existing weights of the input layer and fully connected layer concatenated with convo  $1 \times 1$  and identical block shown in Figure 3.
- Finally, the model was modified by adding average polling to make the image smoother and a fully connected layer with 2048 neurons, allowing the entire network layer to be trained on the new proposed dataset.
- Figure 2 depicts the overall process of image disease prediction, and Figure 3 illustrates the proposed structure of the network.

In addition to that, we used the categorical cross-entropy loss function, which allows picking correct high and low probability digits calculated in Equation (ii).

$$-\frac{1}{N} \sum_{i=1}^N \log \text{Model} [y_i \in C_{y_i}] \quad (ii)$$

The double sum is over the categories " $c$ ," which has several  $C$ , and the observations  $I$ , which have several  $N$ . The signal functions of  $I$  observable about the  $c$  subcategory is known as  $1 y I$  in  $C$ . The probability that  $I$  observable will fall into the  $c$  classification is represented by the "p model" variable [39]. Therefore the developed function is based on the two class classifications in Equation (ii). Where  $F(x, "W_i")$  is the residual block,  $y$  is the outcome function, and  $x$  is the entry to the residual block [40]. Remember that weighted layers are present in the residual block and are denoted by the symbol  $W_i$ , where  $I$  am the number of layers in the residual block.

$$y = F(x, \sigma\{W_i\}) + x \quad (iii)$$

Additionally, the expression  $F(x, W_i)$  for two weight layers in a residual block can be abbreviated as ReLU function  $\sigma$  in Equation (iii).

The proposed model ResNet 50 depicts the connection skipping strategy by giving a convolution with 64 distinct kernels, each with a stride of value 2, and a kernel size of  $7 \times 7$  gives us in first convo layer and a MaxPolling with a 2 stride size. The preceding convolution consists of three layers: a  $1 \times 1, 64$  kernel, a  $3 \times 3, 64$  kernel, and finally, a  $1 \times 1, 256$  kernel. These three levels have been replicated three times, providing nine layers in this phase. The kernel size of  $1 \times 1, 128$  is below in Figure 3, followed by the kernel of  $3 \times 3, 128$  and, finally, the kernel of  $1 \times 1, 512$ . We performed this procedure four times for a total of 12 layers. We have a kernel of size  $1 \times 1, 256$ , followed by two more kernels of size  $3 \times 3, 256$  and size  $1 \times 1, 1024$ . The above process was repeated six times, providing us with 18 layers in total.



Figure 1. Digital labeled sample images of rice leaf diseases and Healthy leaves

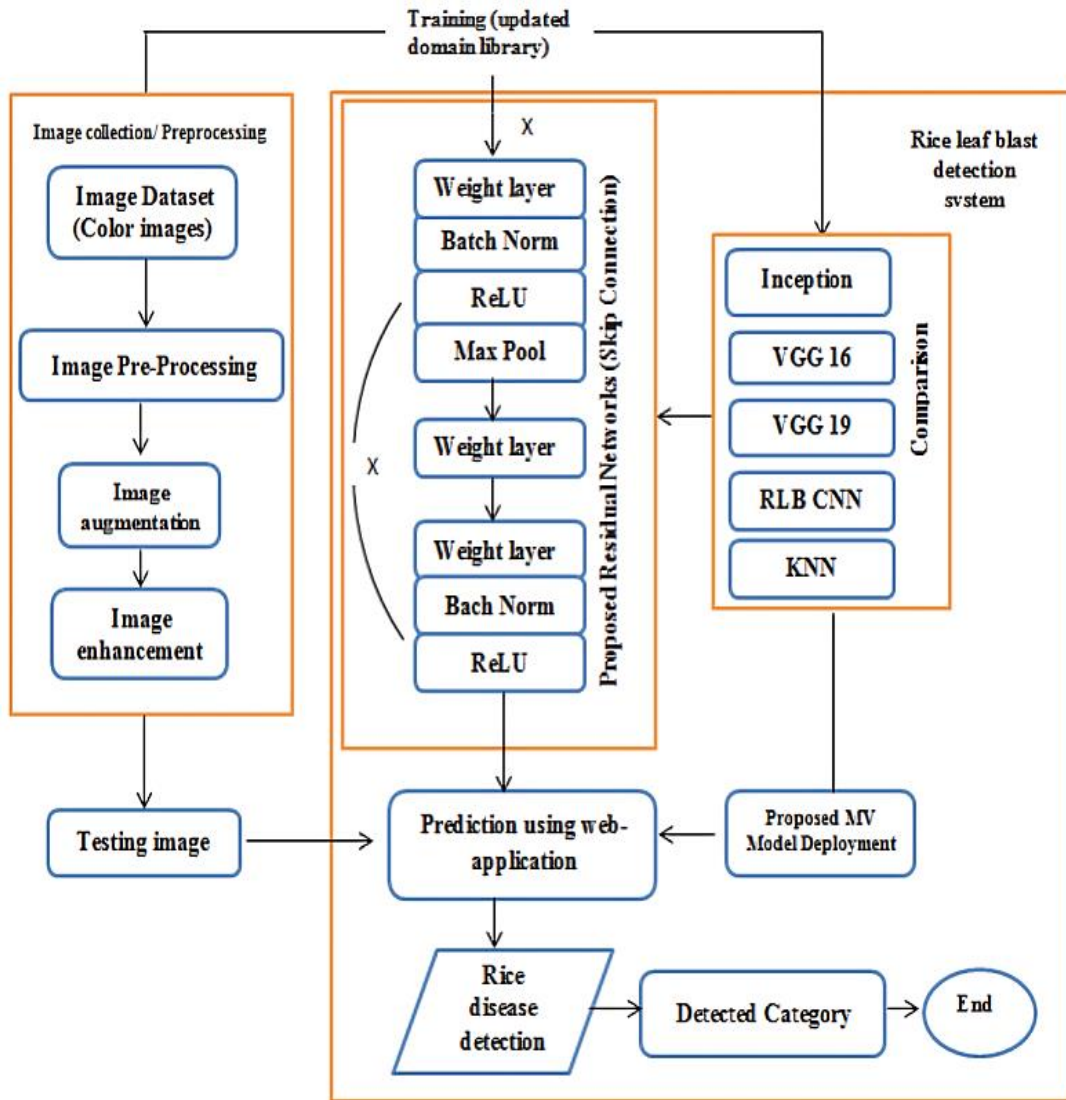

Figure 2. The overall process of rice leaf blast dedetection

Each layer extracted features from an image by accepting the binary matrix from the previous layer as input. After all, a 1\*1 kernel with 512 neurons and 1\*1 with 2048 neurons layer were repeated, giving us more 9 feature map layers shown in Figure 3. At last, we performed an average pool to sharpen the output image, and a fully connected layer with 2 nodes ended up with a Softmax

function giving us 1 layer. In the process of rice leaf blast disease detection, we employed different machine vision and deep learning models using cross-validation techniques to eliminate the complexity of the training and testing ratio.

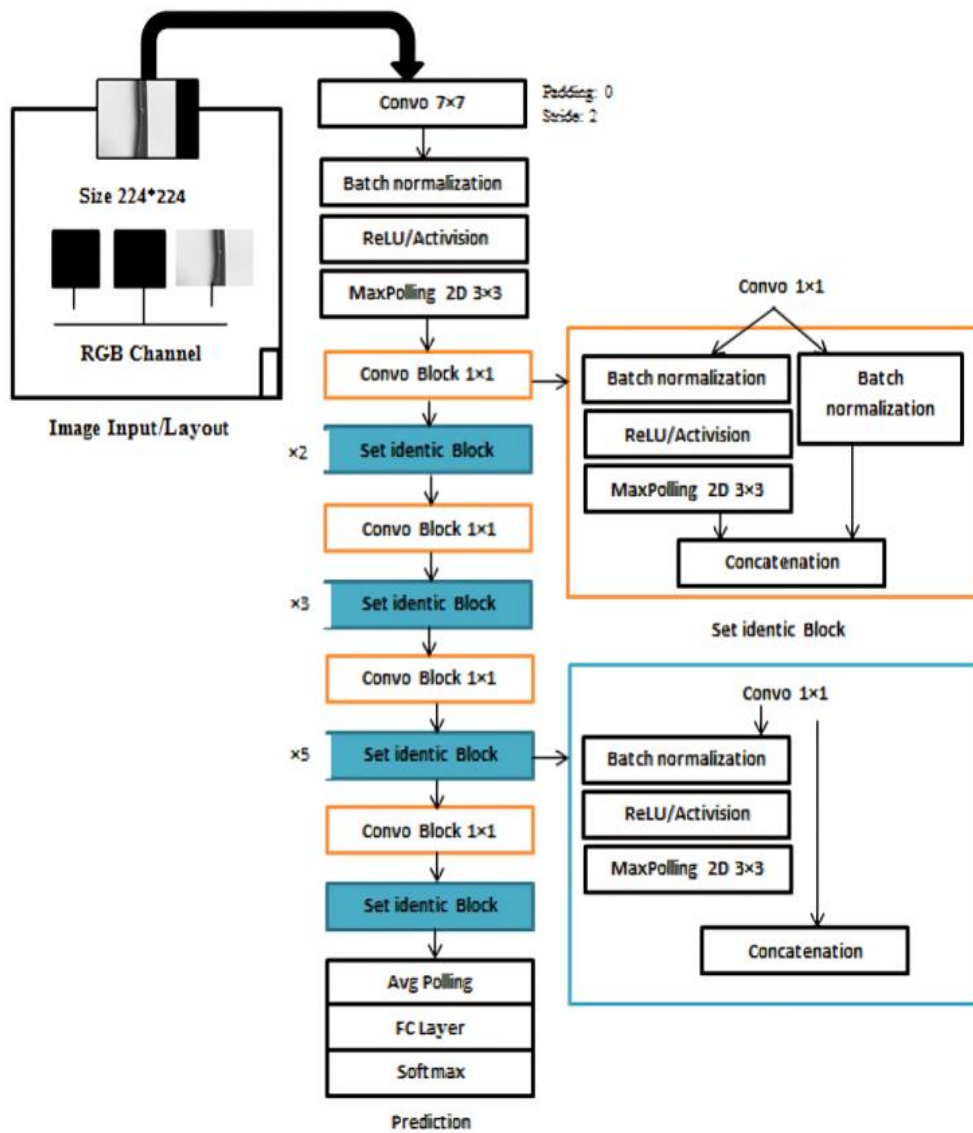

Figure 3. Proposed ResNet 50 architecture

#### 4. Results and discussion

In this paper, we applied different MV classifiers such as ResNet connection skipping, Inception V3, VGG 16, VGG 19, CNN, and an ensemble module KNN to conduct a competitive analysis of rice leaf blast disease

Table 3, it was observed that the connection skipping ResNet network outperformed the rest of the

using an updated rice dataset as shown in Table 4. While implementing predicting module for training and testing, we used (Python 3) and preprocess input function on the collab, to enhance the process of training the deep learning networks allocated with (tesla T4) and model Intel(R) Xeon(R) CPU at 2.20 GHz with 12 Gb of memory. Based on the parameter values depicted in networks in identifying rice leaf blast disease. Moreover, the original imaging data was expanded using the inbuilt

python data gen library for image augmentation. The random values are bounded for rescaling, shear view

zoom range, and vertical flip, as shown in Figure 4.

**Table 3.** Selected parameter values in our experiment.

Parameter	Values
Input layer	1
Optimizer	adam
Validation threshold	20
Epochs	50
Neurons	512

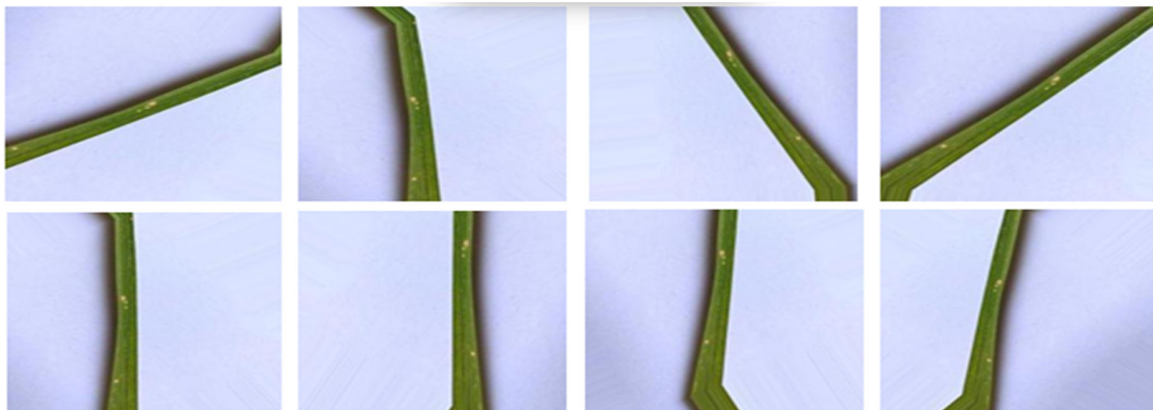

**Figure 4.** Example of augmented rice leaf blast images

These values were distributed among rescaling to 1/.256, shear range to 0.3, and zoom range to 0.2 for an input image. In this scenario, we retained specific numbers of

sample images to monitor the model's effectiveness, as shown in Figure 4

**Table 4.** The overall learning accuracy of different approaches on the public rice dataset.

Model	OA accuracy%	Validation accuracy%	F1-Score%	AUC%	Epochs
Inception V3	97.59	93.77	97.61	98.44	50
VGG 16	97.45	97.91	97	98.01	20
VGG 19	96.49	75.76	94.17	98.91	10
CNN	89.62	79.75	89.62	90.01	30
Ensemble module				K-value	
KNN	81	77	81	10	
Proposed Module	<b>99.75</b>	99.16	99.70	99.83	50

Taking into account the statistics of true positives, false negatives, true negatives, and true positives, you can assess the effectiveness of the models using the metrics of Overall accuracy (OA), Validation accuracy,

F1-Score, AUC (which shows the highest values touching 1) as represented in Table 4. It considers the evaluation statistics to determine the correct and incorrect predictions of the model depicted in Equation (iv). The average accuracy is calculated using true



positive (TP) instances that belong to class 0 and are predicted correctly by the model. False negative (FN) is the total number of values expected as class 0 but belonging to class 1. False positives (FP) are the values mispredicted as class 0. The actual negatives (TN) are the values not in class 0 but predicted correctly as class 0.

$$OA = \frac{TP + TN}{TP + FP + TN + FN} \quad (iv)$$

It was observed that ResNet 50 connection skipping provides promising results on implemented methodology. We used  $224 \times 224$  image size thus to achieve the accuracy values of 97.59%, 97.45%, 96.49%, 89.62%, 81%, and 99.75% by implementing Inception V3, VGG 16, VGG 19, CNN, KNN, and ResNet respectively. Unlike other individual networks, the ResNet transfers

the learning after freezing its entire existing layer to train on our prospected problem. After 50 epochs, the proposed module achieved an overall accuracy of 99.75%, and the F1 score reached 99.70%, as shown in Table 4. Furthermore, Figure 5 describes the confusion matrix after normalization for the corresponding model evaluation. The approach is also evaluated on our testing dataset after deploying our model on the gradio server dashboard to recognize the rice leaf blast disease and a healthy leaf with an average AUC score of 99.83%, and the detected plant category is visualized on an interactive dashboard in Figure 6, which indicating interactive dashboard he validity of proposed architecture.

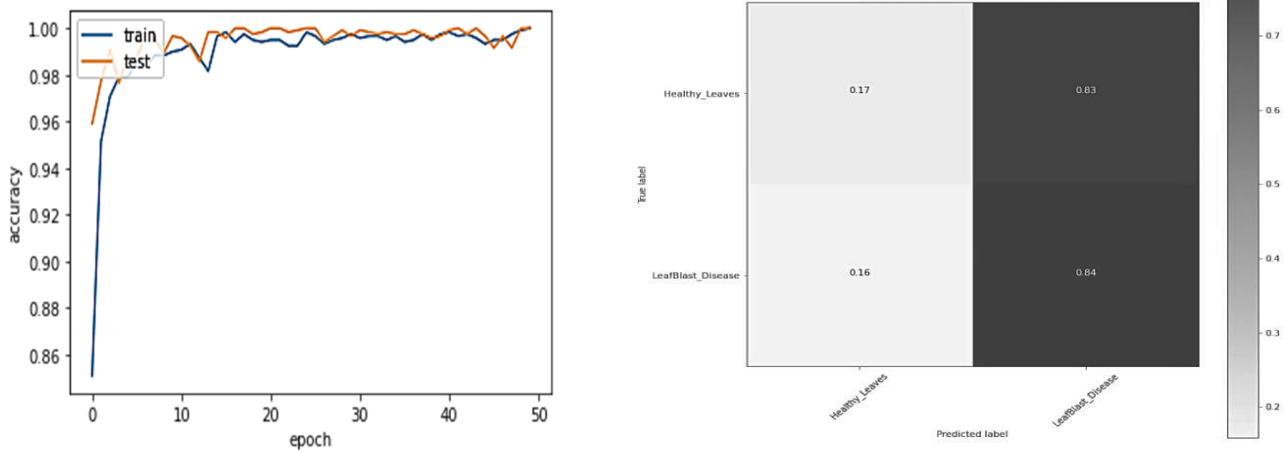

Figure 5. (Left)Accuracy curve and (Right) Normalized Confusion matrix of results

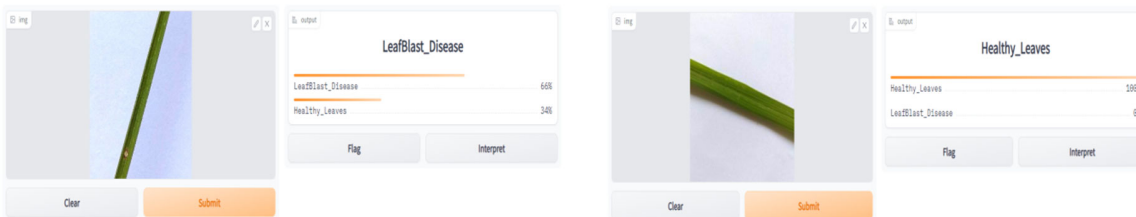

Figure 6 Predicted categories using gradio web-server

## 5. Conclusion

To ensure the productivity of plant foods, the prompt and precise identification of plant leaves diseases is essential. For this purpose, looking out for quick, autonomous, less expensive, and accurate ways to identify rice disease is significant. Therefore, in this paper, a unique deep learning network named ResNet

## References

- [1] S. U. Siddiqui, T. Kumamaru, and H. Satoh, "Pakistan rice genetic resources-I: Grain morphological diversity and its distribution," *Pakistan Journal of Botany*, vol. 39, no. 3, pp. 841-848, 2007.
- [2] H.-u. Rehman, T. Aziz, M. Farooq, A. Wakeel, and Z. Rengel, "Zinc nutrition in rice production systems: a review," *Plant Soil Biology and Biochemistry*, vol. 361, no. 1, pp. 203-226, 2012.
- [3] B. S. Chauhan, K. Jabran, and G. Mahajan, *Rice production worldwide*. Springer, 2017.
- [4] M. Shahbandeh. (2022, 12). *Top countries based on the production of milled rice 2020/21*. Available: <https://www.statista.com/statistics/255945/top-countries-of-destination-for-us-rice-exports-2011/>
- [5] OEC. (2020, 05). *Rice In Pakistan*. Available: <https://oec.world/en/profile/bilateral-product/rice/reporter/pak>
- [6] A. Rehman, L. Jingdong, A. A. Chandio, M. Shabbir, and I. Hussain, "Economic outlook of rice crops in Pakistan: a time series analysis (1970–2015)," *Financial innovation*, vol. 3, no. 1, pp. 1-9, 2017.
- [7] T. Uzzaman, R. Sikder, M. Asif, H. Mehraj, and A. J. Uddin, "Growth and yield trial of sixteen rice varieties under System of Rice Intensification," *Sci Agric*, vol. 11, no. 2, pp. 81-89, 2015.
- [8] C. R. Rahman *et al.*, "Identification and recognition of rice diseases and pests using convolutional neural networks," *Biosystems Engineering*, vol. 194, pp. 112-120, 2020.
- [9] A. Kaur, K. Guleria, and N. K. Trivedi, "Rice Leaf Disease Detection: A Review," in *2021 6th International Conference on Signal Processing, Computing and Control (ISPCC)*, 2021, pp. 418-422: IEEE.
- [10] H. B. Prajapati, J. P. Shah, and V. K. Dabhi, "Detection and classification of rice plant diseases," *Intelligent Decision Technologies*, vol. 11, no. 3, pp. 357-373, 2017.
- connection skipping is suggested to identify rice leaf blast disease by freezing the existing weights of the input layer and introducing a fully connected layer concatenated with convo 1×1 and identical block with predicting several classes. All the models performed well, but ResNet connection skipping excelled with notable results by achieving 99.75% accuracy on the rice plant disease dataset
- [11] L. Nalley, F. Tsiboe, A. Durand-Morat, A. Shew, and G. Thoma, "Economic and environmental impact of rice blast pathogen (*Magnaporthe oryzae*) alleviation in the United States," *PLoS one*, vol. 11, no. 12, p. e0167295, 2016.
- [12] C. Duku, A. H. Sparks, and S. J. Zwart, "Spatial modeling of rice yield losses in Tanzania due to bacterial leaf blight and leaf blast in a changing climate," *Climatic change*, vol. 135, no. 3, pp. 569-583, 2016.
- [13] C. Szegedy, V. Vanhoucke, S. Ioffe, J. Shlens, and Z. Wojna, "Rethinking the inception architecture for computer vision," in *Proceedings of the IEEE conference on computer vision and pattern recognition*, 2016, pp. 2818-2826.
- [14] B. Kien *et al.*, "Crack detection of plastic gears using a convolutional neural network pre-learned from images of meshing vibration data with transfer learning," *Forschung in Ingenieurwesen*, vol. 83, no. 3, pp. 645-653, 2019.
- [15] M. Abdullah, S. Ghazanfar, J. Ahmed, and I. Khan, "Growth and instability analysis of rice production and export of Pakistan," *European Journal of Economic Studies*, no. 1, pp. 4-15, 2015.
- [16] S. Kouser and K. Mushtaq, "Environmental efficiency analysis of basmati rice production in Punjab, Pakistan: Implications for sustainable agricultural development," *The Pakistan Development Review*, pp. 57-72, 2010.
- [17] K. Ahmed, T. R. Shahidi, S. M. I. Alam, and S. Momen, "Rice leaf disease detection using machine learning techniques," in *2019 International Conference on Sustainable Technologies for Industry 4.0 (STI)*, 2019, pp. 1-5: IEEE.
- [18] Y. Lu, S. Yi, N. Zeng, Y. Liu, and Y. Zhang, "Identification of rice diseases using deep convolutional neural networks," *Neurocomputing*, vol. 267, pp. 378-384, 2017.
- [19] W.-j. Liang, H. Zhang, G.-f. Zhang, and H.-x. Cao, "Rice blast disease recognition using a deep convolutional neural network," *Scientific reports of cetacean research*, vol. 9, no. 1, pp. 1-10, 2019.
- [20] S. Qadri *et al.*, "Machine Vision Approach for Classification of Rice Varieties Using Texture

- Features," *International Journal of Food Properties*, vol. 24, no. 1, pp. 1615-1630, 2021.
- [21] M. S. Irshad, Q. Xin, and H. Arshad, "Competitiveness of Pakistani rice in international market and export potential with the global world: A panel gravity approach," *Cogent Economics Finance*, vol. 6, no. 1, p. 1486690, 2018.
- [22] J. Chen, D. Zhang, Y. A. Nanekaran, and D. Li, "Detection of rice plant diseases based on deep transfer learning," *Journal of the Science of Food Agriculture*, vol. 100, no. 7, pp. 3246-3256, 2020.
- [23] J. Q. Yuan, L. Li, and W. Yan, "Early Identification of Rice Leaf Blast Based on Hyperspectral Imaging," in *Journal of Physics: Conference Series*, 2021, vol. 1944, no. 1, p. 012041: IOP Publishing.
- [24] K. Kiratiratanapruk, P. Temniranrat, A. Kitvimonrat, W. Sinthupinyo, and S. Patarapuwadol, "Using deep learning techniques to detect rice diseases from images of rice fields," in *International Conference on Industrial, Engineering and Other Applications of Applied Intelligent Systems*, 2020, pp. 225-237: Springer.
- [25] P. K. Sethy, N. K. Barpanda, A. K. Rath, and S. K. Behera, "Deep feature based rice leaf disease identification using support vector machine," *Computers Electronics in Agriculture*, vol. 175, p. 105527, 2020.
- [26] G. Zhou, W. Zhang, A. Chen, M. He, and X. Ma, "Rapid detection of rice disease based on FCM-KM and faster R-CNN fusion," *IEEE Access*, vol. 7, pp. 143190-143206, 2019.
- [27] H. Yang, J. Ni, J. Gao, Z. Han, and T. Luan, "A novel method for peanut variety identification and classification by Improved VGG16," *Scientific Reports* vol. 11, no. 1, pp. 1-17, 2021.
- [28] M. Uzair, S. S. Sohail, N. U. Shaikh, and A. Shan, "Agricultural residue as an alternate energy source: A case study of Punjab province, Pakistan," *Renewable Energy*, vol. 162, pp. 2066-2074, 2020.
- [29] S. Frolking *et al.*, "Combining remote sensing and ground census data to develop new maps of the distribution of rice agriculture in China," *Global Biogeochemical Cycles*, vol. 16, no. 4, pp. 38-1-38-10, 2002.
- [30] D. Mohapatra, J. Tripathy, and T. K. Patra, "Rice disease detection and monitoring using CNN and Naive Bayes classification," in *Soft Computing Techniques and Applications*: Springer, 2021, pp. 11-29.
- [31] A. A. Joshi and B. Jadhav, "Monitoring and controlling rice diseases using Image processing techniques," in *2016 International Conference on Computing, Analytics and Security Trends (CAST)*, 2016, pp. 471-476: IEEE.
- [32] A. I. Khan and S. Al-Habsi, "Machine learning in computer vision," *Procedia Computer Science*, vol. 167, pp. 1444-1451, 2020.
- [33] M. H. Masood, H. Saim, M. Taj, and M. M. Awais, "Early disease diagnosis for rice crop," *arXiv preprint* 2020.
- [34] K. Bashir, M. Rehman, and M. Bari, "Detection and classification of rice diseases: An automated approach using textural features," *Mehran University Research Journal of Engineering Technology*, vol. 38, no. 1, pp. 239-250, 2019.
- [35] M. R. Larijani, E. A. Asli-Ardeh, E. Kozegar, and R. Loni, "Evaluation of image processing technique in identifying rice blast disease in field conditions based on KNN algorithm improvement by K-means," *Food science nutrition*, vol. 7, no. 12, pp. 3922-3930, 2019.
- [36] Z. Jiang, Z. Dong, W. Jiang, and Y. Yang, "Recognition of rice leaf diseases and wheat leaf diseases based on multi-task deep transfer learning," *Computers Electronics in Agriculture*, vol. 186, p. 106184, 2021.
- [37] Shareef. (2021, 4 Jun). *Rice Leaf Disease Dataset* Available: <https://www.kaggle.com/code/asheniranga/notebook7fe71548bd>
- [38] S. A. Shahriar, A. A. Imtiaz, M. B. Hossain, A. Husna, and M. N. K. Eaty, "Rice blast disease," *Annual Research Review in Biolog*, pp. 50-64, 2020.
- [39] J. Chen, D. Zhang, Y. A. Nanekaran, and D. Li, "Detection of rice plant diseases based on deep transfer learning," *Journal of the Science of Food Agriculture*, vol. 100, no. 7, pp. 3246-3256, 2020.
- [40] H. D. Prasetyo, H. Triatmoko, and I. N. Isnainiyah, "The Implementation of CNN on Website-based Rice Plant Disease Detection," in *2020 International Conference on Informatics, Multimedia, Cyber and Information System (ICIMCIS)*, 2020, pp. 75-80: IEEE.